

Physics
Standard level
Paper 1

Friday 6 May 2016 (morning)

45 minutes

Instructions to candidates

- Do not open this examination paper until instructed to do so.
- Answer all the questions.
- For each question, choose the answer you consider to be the best and indicate your choice on the answer sheet provided.
- A clean copy of the **physics data booklet** is required for this paper.
- The maximum mark for this examination paper is **[30 marks]**.

1. A sphere fits inside a cube.

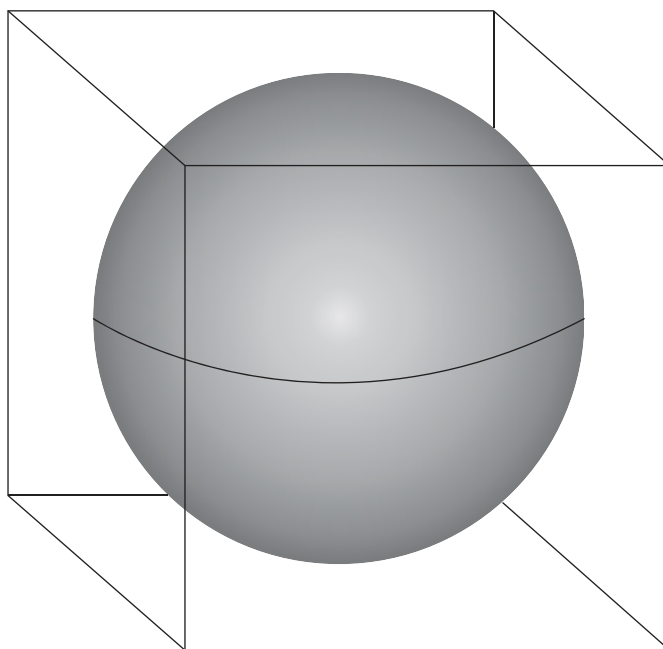

The length of the cube and the diameter of the sphere are 10.0 ± 0.2 cm.

What is the ratio $\frac{\text{percentage uncertainty of the volume of the sphere}}{\text{percentage uncertainty of the volume of the cube}}$?

- A. $\frac{3}{4\pi}$
- B. 1
- C. 2
- D. 8
2. A swimming pool contains 18×10^6 kg of pure water. The molar mass of water is 18 g mol^{-1} . What is the correct estimate of the number of water molecules in the swimming pool?
- A. 10^4
- B. 10^{24}
- C. 10^{25}
- D. 10^{33}

3. An aircraft is moving horizontally. A parachutist leaves the aircraft and a few seconds later opens her parachute. Which graph shows the variation of the vertical speed v with time t for the parachutist from the time she leaves the aircraft until just before landing?

A.

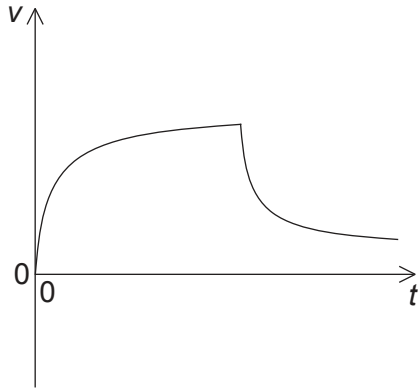

B.

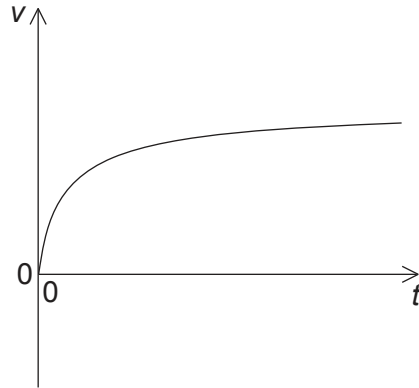

C.

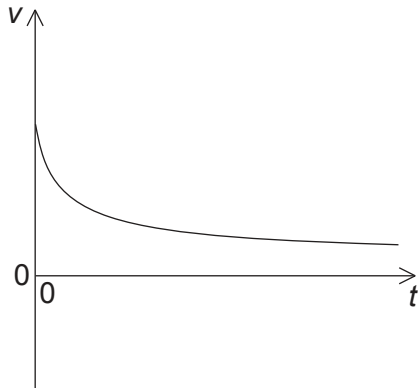

D.

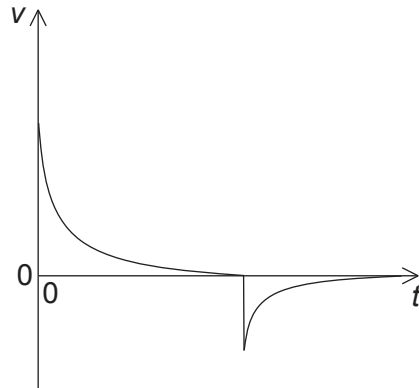

4. An object of mass m rests on a horizontal plane. The angle θ that the plane makes with the horizontal is slowly increased from zero. When $\theta = \theta_0$, the object begins to slide. What are the coefficient of static friction μ_s and the normal reaction force N of the plane at $\theta = \theta_0$?

	μ_s	N
A.	$\sin \theta_0$	$mg \cos \theta_0$
B.	$\tan \theta_0$	$mg \sin \theta_0$
C.	$\sin \theta_0$	$mg \sin \theta_0$
D.	$\tan \theta_0$	$mg \cos \theta_0$

Turn over

5. A stone is falling at a constant velocity vertically down a tube filled with oil. Which of the following statements about the energy changes of the stone during its motion are correct?
- I. The gain in kinetic energy is less than the loss in gravitational potential energy.
 - II. The sum of kinetic and gravitational potential energy of the stone is constant.
 - III. The work done by the force of gravity has the same magnitude as the work done by friction.
- A. I and II only
 - B. I and III only
 - C. II and III only
 - D. I, II and III
6. A spring of negligible mass and length l_0 hangs from a fixed point. When a mass m is attached to the free end of the spring, the length of the spring increases to l . The tension in the spring is equal to $k\Delta x$, where k is a constant and Δx is the extension of the spring. What is k ?
- A. $\frac{mg}{l_0}$
 - B. $\frac{mg}{l}$
 - C. $\frac{mg}{l-l_0}$
 - D. $\frac{mg}{l_0-l}$

7. A ball with mass m moves horizontally with speed u . The ball hits a vertical wall and rebounds in the opposite direction with speed $v < u$. The duration of the collision is T . What are the magnitude of the average force exerted by the wall on the ball and the loss of kinetic energy of the ball?

	Average force	Loss of kinetic energy
A.	$\frac{m(u+v)}{T}$	$\frac{m(u^2 - v^2)}{2}$
B.	$\frac{m(u+v)}{T}$	$\frac{m(u-v)^2}{2}$
C.	$\frac{m(u-v)}{T}$	$\frac{m(u^2 - v^2)}{2}$
D.	$\frac{m(u-v)}{T}$	$\frac{m(u-v)^2}{2}$

8. A train on a straight horizontal track moves from rest at constant acceleration. The horizontal forces on the train are the engine force and a resistive force which increases with speed. Which graph represents the variation with time t of the power P developed by the engine?

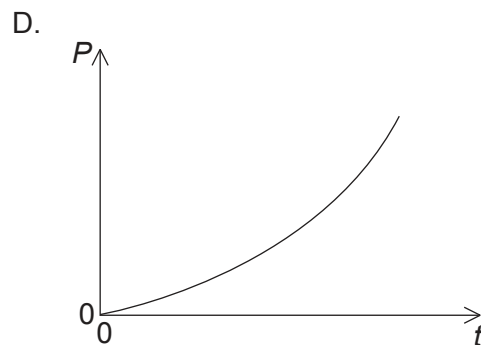
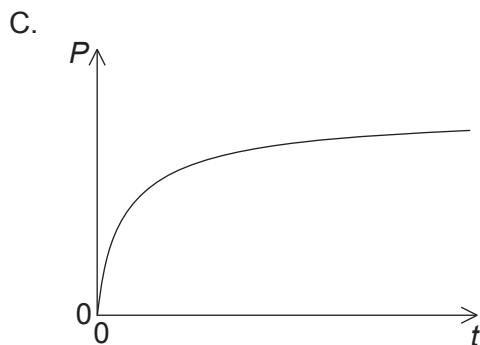
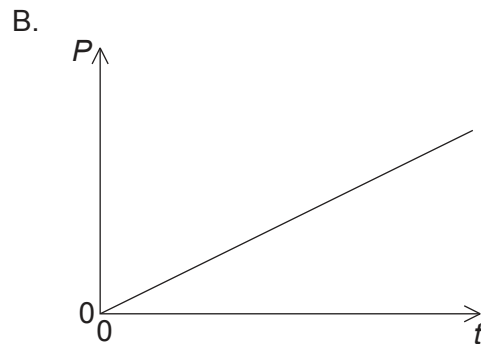
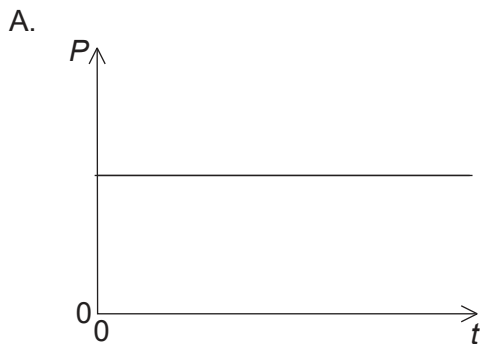

Turn over

9. The graph shows how the acceleration a of an object varies with distance travelled x .

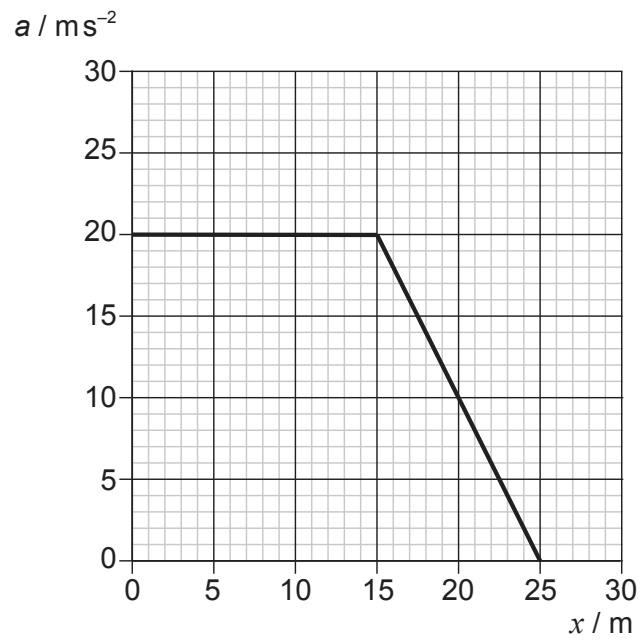

The mass of the object is 3.0 kg. What is the total work done on the object?

- A. 300 J
- B. 400 J
- C. 1200 J
- D. 1500 J

10. A substance is heated at constant power. The graph shows how the temperature T of the substance varies with time t as the state of the substance changes from liquid to gas.

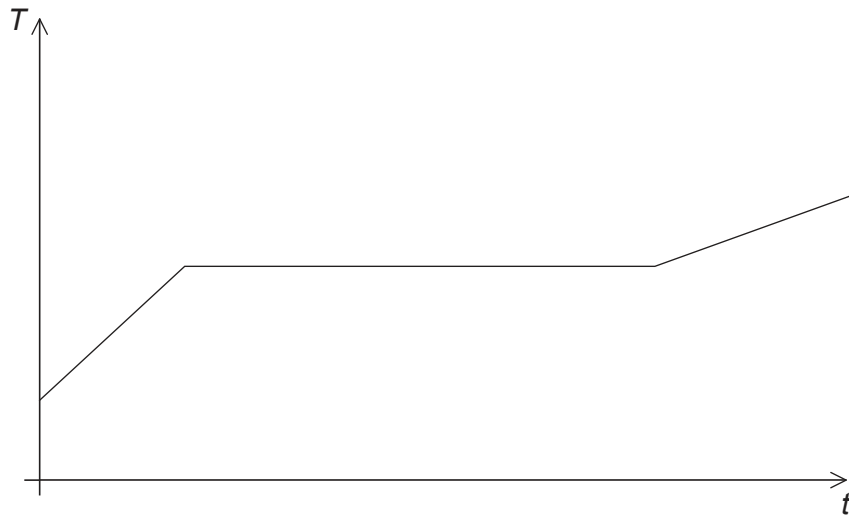

What can be determined from the graph?

- A. The specific heat capacity of the gas is smaller than the specific heat capacity of the liquid.
 - B. The specific heat capacity of the gas is larger than the specific heat capacity of the liquid.
 - C. The specific latent heat of fusion of the substance is less than its specific latent heat of vaporization.
 - D. The specific latent heat of fusion of the substance is larger than its specific latent heat of vaporization.
11. Which of the following is **not** an assumption of the kinetic model of ideal gases?
- A. All particles in the gas have the same mass.
 - B. All particles in the gas have the same speed.
 - C. The duration of collisions between particles is very short.
 - D. Collisions with the walls of the container are elastic.

Turn over

12. Under what conditions of density and pressure is a real gas best described by the equation of state for an ideal gas?
- A. Low density and low pressure
 - B. Low density and high pressure
 - C. High density and low pressure
 - D. High density and high pressure
13. A point source emits sound waves of amplitude A . The sound intensity at a distance d from the source is I . What is the sound intensity at a distance $0.5d$ from the source when the source emits waves of amplitude $2A$?
- A. $16I$
 - B. $4I$
 - C. I
 - D. $\frac{1}{4}I$

14. A water wave moves on the surface of a lake. P and Q are two points on the water surface. The wave is travelling towards the right.

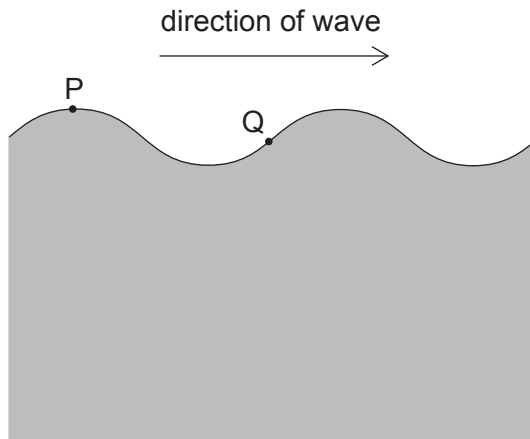

The diagram shows the wave at time $t=0$. Which graph shows how the displacements of P and Q vary with t ?

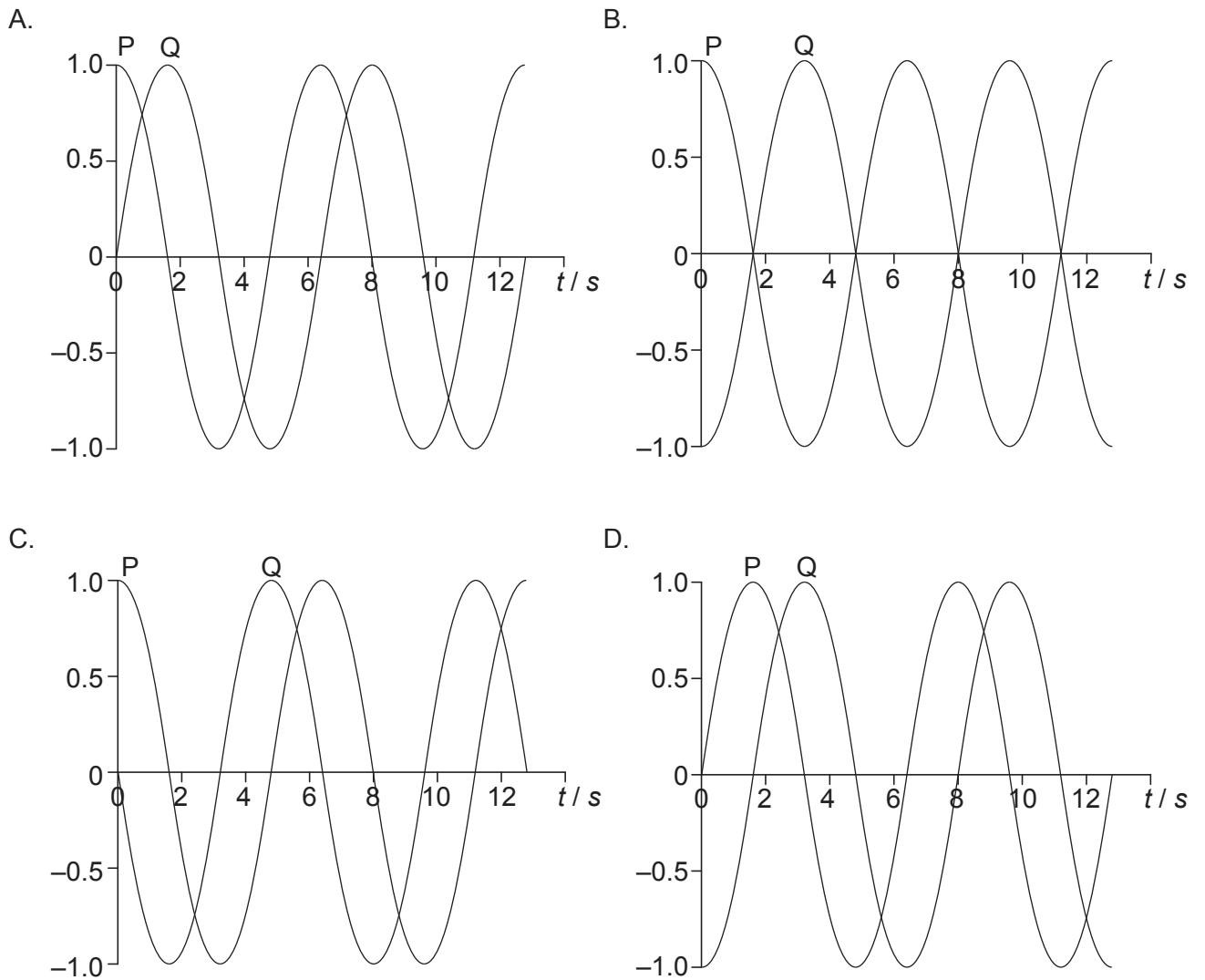

Turn over

15. Horizontally polarized light of intensity I_0 enters a polarizer P whose polarization axis makes an angle of θ degrees with the horizontal. Light from P is then incident on a polarizer A with fixed vertical polarization axis.

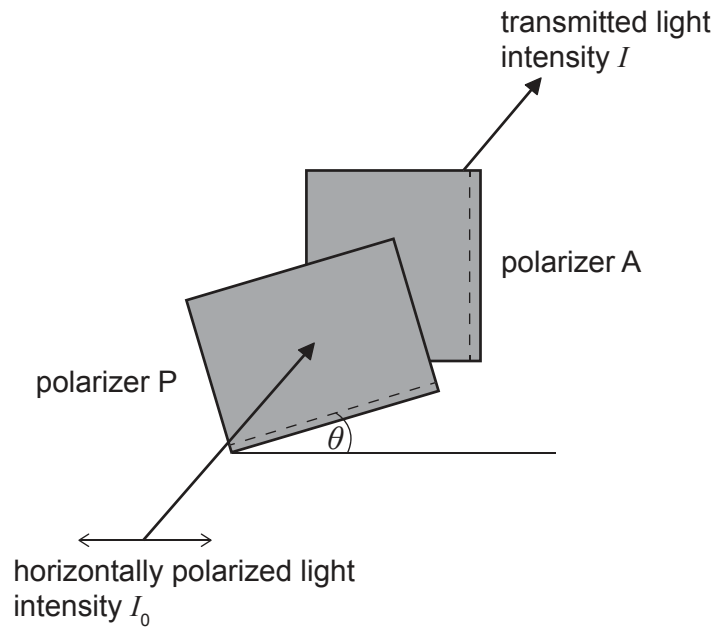

The angle θ is varied from 0 to 90 degrees. Which of the following represents the variation with θ of the intensity I of the light transmitted through A?

A.

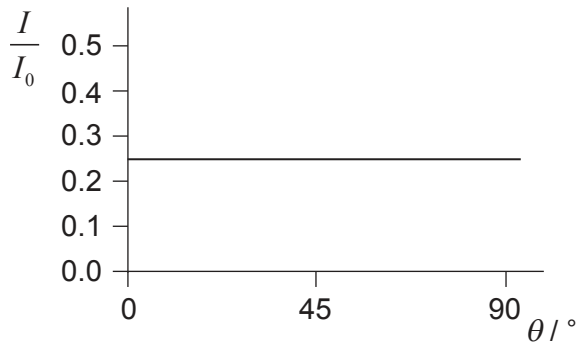

B.

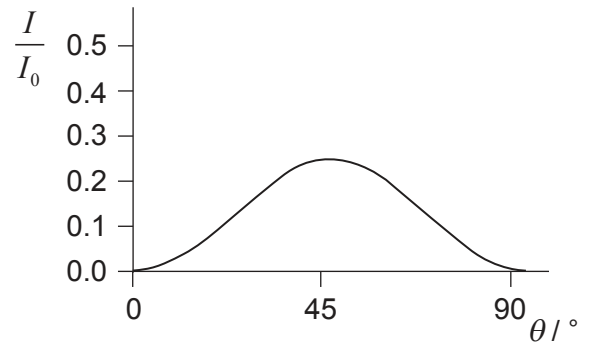

C.

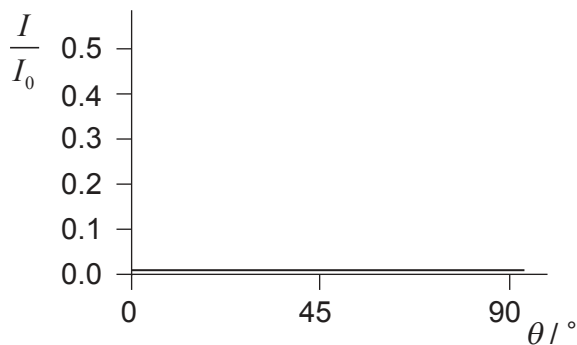

D.

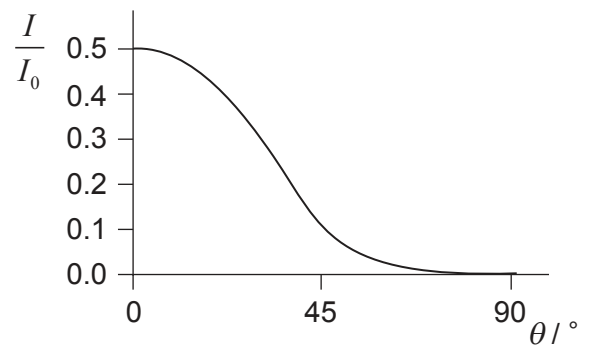

16. A pipe of length L has two open ends. Another pipe of length L' has one open end and one closed end.

The frequency of the first harmonic of both pipes is the same. What is $\frac{L'}{L}$?

- A. 2
- B. $\frac{3}{2}$
- C. 1
- D. $\frac{1}{2}$

17. A light ray passes from air to water as shown.

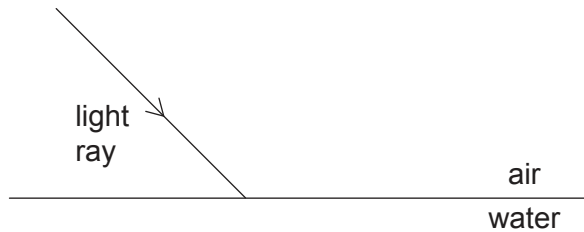

What are the change in the wavelength of the light wave and the change in the angle the ray makes with the normal to the surface?

	Wavelength	Angle with normal
A.	increases	increases
B.	increases	decreases
C.	decreases	increases
D.	decreases	decreases

Turn over

18. Three fixed charges, $+Q$, $-Q$ and $-2Q$, are at the vertices of an equilateral triangle. What is the resultant force on an electron at the centre of the triangle?

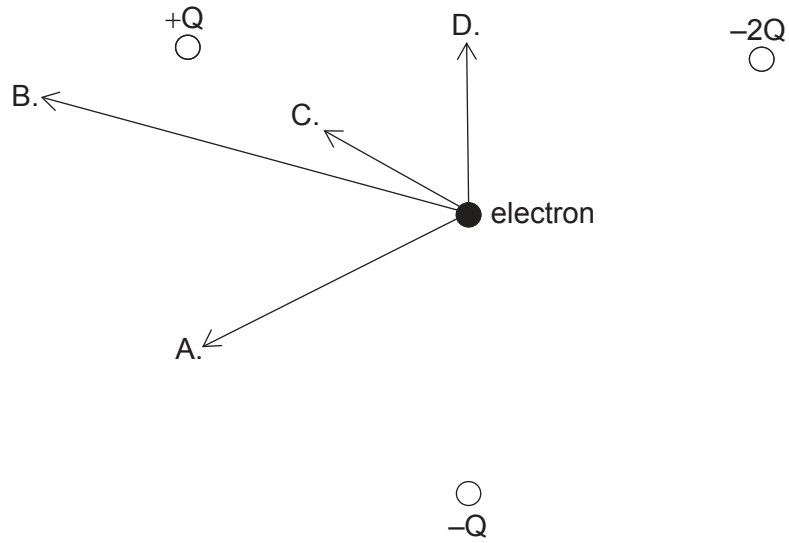

19. The graph shows the variation of current I in a device with potential difference V across it.

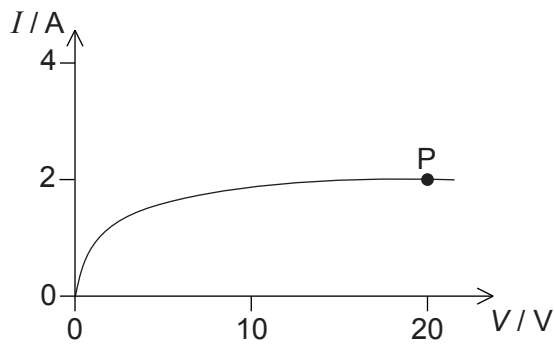

What is the resistance of the device at P?

- A. zero
- B. 0.1Ω
- C. 10Ω
- D. infinite

20. A circuit consists of a cell of electromotive force (emf) 6.0V and negligible internal resistance connected to two resistors of 4.0Ω .

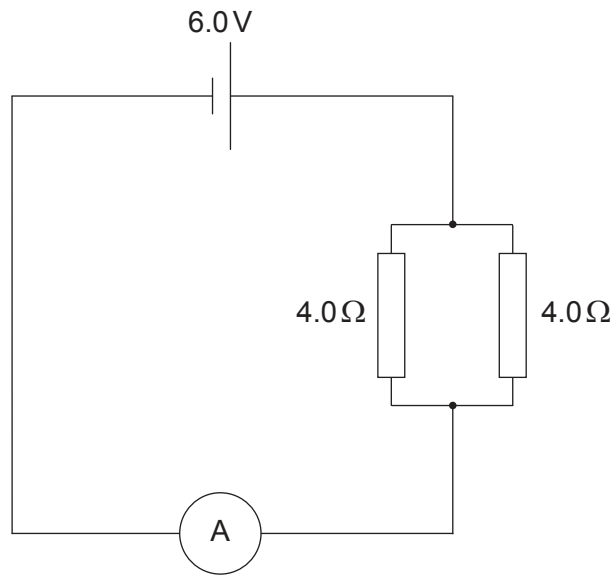

The resistance of the ammeter is 1.0Ω . What is the reading of the ammeter?

- A. 2.0A
- B. 3.0A
- C. 4.5A
- D. 6.0A

Turn over

21. A wire carrying a current I is placed in a region of uniform magnetic field B , as shown in the diagram.

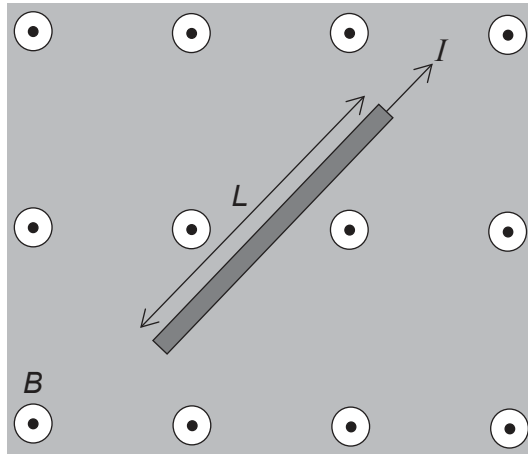

The direction of the field B is out of the page and the length of the wire is L . What is correct about the direction and magnitude of the force acting on the wire?

	Direction	Magnitude
A.		equal to BIL
B.		smaller than BIL
C.		equal to BIL
D.		smaller than BIL

22. A mass connected to one end of a rigid rod rotates at constant speed in a vertical plane about the other end of the rod.

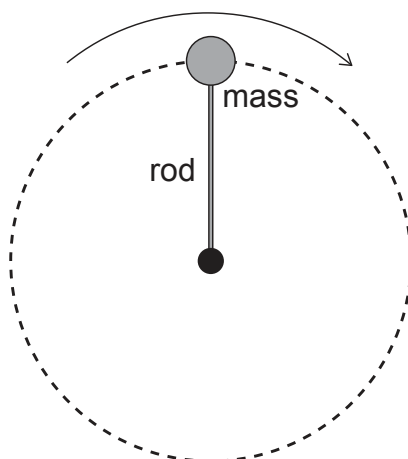

The force exerted by the rod on the mass is

- A. zero everywhere.
 - B. constant in magnitude.
 - C. always directed towards the centre.
 - D. a minimum at the top of the circular path.
23. Planet X has mass M and radius R . Planet Y has mass $2M$ and radius $3R$. The gravitational field strength at the surface of planet X is g . What is the gravitational field strength at the surface of planet Y?
- A. $\frac{2}{9}g$
 - B. $\frac{2}{3}g$
 - C. $\frac{3}{2}g$
 - D. $\frac{9}{2}g$

Turn over

24. A simple model of an atom has five energy levels. What is the maximum number of different frequencies in the emission spectrum of that atom?
- A. 4
 - B. 6
 - C. 10
 - D. 25
25. Which of the following is the correct definition of the binding energy of a nucleus?
- A. The product of the binding energy per nucleon and the nucleon number
 - B. The minimum work required to completely separate the nucleons from each other
 - C. The energy that keeps the nucleus together
 - D. The energy released during the emission of an alpha particle
26. Which of the following lists three fundamental forces in increasing order of strength?
- A. electromagnetic, gravity, strong nuclear
 - B. weak nuclear, gravity, strong nuclear
 - C. gravity, weak nuclear, electromagnetic
 - D. electromagnetic, strong nuclear, gravity
27. For which reason were quarks first introduced?
- A. To explain the existence of isotopes
 - B. To describe nuclear emission and absorption spectra
 - C. To account for patterns in properties of elementary particles
 - D. To account for the missing energy and momentum in beta decay

28. A solar panel has surface area 0.40 m^2 and efficiency 50%. The average intensity of radiation reaching the surface of the panel is 0.25 kW m^{-2} . What is the average power output from an array of 10 of these solar panels?
- A. 0.5W
 - B. 5W
 - C. 50W
 - D. 500W
29. What is the correct order of energy transformations in a coal power station?
- A. thermal \rightarrow chemical \rightarrow kinetic \rightarrow electrical
 - B. chemical \rightarrow thermal \rightarrow kinetic \rightarrow electrical
 - C. chemical \rightarrow kinetic \rightarrow thermal \rightarrow electrical
 - D. kinetic \rightarrow chemical \rightarrow electrical \rightarrow thermal
30. A black body of surface 1.0 m^2 emits electromagnetic radiation of peak wavelength $2.90 \times 10^{-6}\text{ m}$. Which of the following statements about the body are correct?
- I. The temperature of the body is 1000 K.
 - II. The energy radiated by the body in one second is $5.7 \times 10^4\text{ J}$.
 - III. The body is a perfect absorber of electromagnetic radiation.
- A. I and II only
 - B. I and III only
 - C. II and III only
 - D. I, II and III
-